



5500W 110/230V GENERATOR 13HP - 4-STROKE ENGINE

MODEL NO: **G5501.V2**

Thank you for purchasing a Sealey product. Manufactured to a high standard, this product will, if used according to these instructions, and properly maintained, give you years of trouble free performance.

IMPORTANT: PLEASE READ THESE INSTRUCTIONS CAREFULLY. NOTE THE SAFE OPERATIONAL REQUIREMENTS, WARNINGS & CAUTIONS. USE THE PRODUCT CORRECTLY AND WITH CARE FOR THE PURPOSE FOR WHICH IT IS INTENDED. FAILURE TO DO SO MAY CAUSE DAMAGE AND/OR PERSONAL INJURY AND WILL INVALIDATE THE WARRANTY. KEEP THESE INSTRUCTIONS SAFE FOR FUTURE USE.



Refer to instruction manual



Warning



Wear ear protection



Hot surfaces



Warning Electricity



Only for use in well-ventilated areas



Keep away from rain



No open flame



Switch off the engine before refuelling



No oil in unit add oil

1. SAFETY

- WARNING!** Ensure any Health & Safety, Government, or local authority regulations are adhered to when using this equipment.
- ✓ Familiarise yourself with the application and limitations, as well as the potential hazards, of the generator.
- ✓ Maintain the generator in good condition (use an authorised service agent). Replace or repair damaged parts. Use genuine parts only. Unauthorised parts may be dangerous and will invalidate the warranty.
- ✓ This generator is designed and manufactured for specific applications. **DO NOT** attempt to modify the unit or use it for any application for which it is not designed. If you have any questions regarding the application of the unit please contact your local Sealey stockist.
- WARNING! DO NOT** exceed the Wattage/Amperage capacity of the generator. Add rated wattage of all devices intended for connection at any one time, the total must not exceed rated wattage of generator (see specifications).
- WARNING!** Generator exhaust gases contain deadly carbon monoxide which must not be inhaled. Always allow sufficient ventilation.
- WARNING!** Some parts of the internal combustion engine are hot and may cause burns. Pay attention to the warnings on the generating set.
- WARNING!** This is a heavy and unbalanced object. Handle with care and use two people when required.
- ▲ **DANGER!** If this unit is used for back-up power in the event of a commercial power failure, the following steps must be taken. Before connecting the generator to the electrical system, open the main circuit breaker to isolate the generator and system from the commercial electric supply. Failure to do this may result in damage to the generator and may result in serious injury or fatality, due to a back-feed of electrical energy.
- ▲ **DANGER!** The generator produces a very powerful voltage that can cause a severe electrical shock. Avoid contact with bare wires, terminals etc. Never allow any unqualified person to operate or service the generator.
- WARNING!** Petrol is flammable. Do not permit smoking, naked flames, sparks or heat in the vicinity while handling Diesel. Avoid spilling Diesel onto a hot engine. Comply with all laws regulating storage and handling of fuels.
- WARNING!** Risk of burns. **DO NOT** touch the exhaust system or the drive unit.
- WARNING! NEVER** refuel when the engine is running or when the engine is hot. Allow cool down time.
- ✓ Operate the generator only on level surfaces (maximum allowable tilt is 10°) and where it will not be exposed to excessive moisture, dirt or corrosive vapours or be in the proximity of combustible material (flammable liquids, solids or gases).
- ✗ **DO NOT** tip or change the generator's position whilst it is operating.
- ✓ Remove ill fitting clothing, ties, watches, rings and other loose jewellery and contain long hair. Wear appropriate protective clothing.
- ✓ Protect children by keeping them at a safe distance from the generating set.
- WARNING!** Never start or stop the generator while electrical loads are connected. Start the engine, let it stabilise, then connect the electrical load. To stop engine, disconnect the electrical load and let engine stabilise before switching off.
- WARNING! DO NOT** use worn, bare, frayed or otherwise damaged electrical cables with the generator. To do so may result in electric shock.
- WARNING!** Only use in well-ventilated areas to reduce risk of suffocation.
- ✗ **DO NOT** use the generator for any purpose other than that for which it is designed.
- ✗ **DO NOT** operate the generator if any parts are missing or damaged, as this may cause failure and/or personal injury.
- ✗ **DO NOT** over-fill fuel tank. Always leave room for fuel to expand. Fuel is combustible and easily ignited. **DO NOT** refuel during operation. **DO NOT** refuel while smoking or near naked flames. **DO NOT** spill fuel.
- ✗ **DO NOT** operate in the rain.
- ▲ **DANGER! DO NOT** tamper with the engine governed speed setting. Higher operating speeds are dangerous and increase the risk of personal injury and/or equipment damage. The generator supplies the correct rated frequencies and voltage only when running at the correct governed speed. Incorrect frequency and/or voltage can damage some connected electrical loads. Operating at excessively low speeds may result in shortened engine life. Over-speeding will invalidate the warranty.
- ✗ **DO NOT** operate the generator when you are tired, or under the influence of alcohol, drugs or intoxicating medication.

- ✘ **DO NOT** store generator with fuel in tank where petrol vapours might reach an open flame or spark.
- ✘ To avoid carbon monoxide poisoning **DO NOT** use Petrol- powered equipment inside any of the following; Home, garage, tent, camper van, mobile home, caravan or boat. This list is not exhaustive and if you are in any doubt contact your Sealey stockist.
- ✓ Dispose of wast oil in accordance with local authority regulations’.
- ✓ Some parts of the internal combustion engine are hot and may cause burns. Pay attention to the warnings on the generating set.

1.1. ELECTRICAL SAFETY

- ✓ Before use, the generating set and its electrical equipment should be checked to ensure that they are not defective.
- ✘ The generating set shall not be connected to other power sources, such as the power company supply mains.
- ✓ Protection against electrical shock depends on circuit breakers specially matched to the generating set. If the circuit breakers require replacement, they should be replaced with a circuit breaker having identical ratings and performances characteristics. Due to high mechanical stresses, only tough rubber-sheathed flexible cable or the equivalent should be used.
- ✓ When using extension lines or mobile distribution networks the resistance value shall not exceed 1,5 Ω.
- ✓ The choice of protection arrangement to be carried out depending on characteristic of the generator, running conditions and scheme of grounded liaisons determined by the user.

1.2. FIRE AND BURN HAZARDS

- The exhaust system gets hot enough to ignite some materials.
- ✓ Keep the generator at least one meter away from buildings and other equipment during operation and maintenance.
- ✘ **DO NOT** enclose the generator in any structure.
- ✓ Keep flammable materials away from the generator.
- ✓ The exhaust becomes very hot during operation and remains hot for a while after stopping the engine. Be careful not to touch the exhaust whilst is hot. Let the generator cool before storing the generator indoors.
- ✓ Petrol is extremely flammable and explosive under certain conditions. **DO NOT** smoke or allow sparks where the generator is refuelled or where the petrol is stored. Refuel in a well-ventilated area with the engine stopped.
- ✓ Fuel vapours are extremely flammable and may ignite after the engine is started. Make sure that any spilled fuel has been wiped off before starting the engine.
- ✓ Always use Class C fire extinguisher that are specifically designed for fires involving energised electrical equipment.

2. INTRODUCTION

Large 25L tank will provide power for up to 9 hours, perfect for use on job sites and in workshops. Electric start allows the generators to be started effortlessly. Also features a recoil start as backup. To maximise the lifespan of the generator, it features low engine oil light, overload protection and DC circuit breaker. Features 2 x 230V 16A, 2 x 110V 16A and 12V DC outputs. Fold-out handles make the generator easy to move and position, coupled with the solid plastic wheels. Powerful and reliable generator fitted with heavy-duty frame, anti-vibration engine mounts and feet.

3. SPECIFICATION

Model No:	G5501
Continuous Power Rating:	5000W
Current Rating:	16A
Dimensions (W x D x H):	690 x 550 x 555mm
Fuel Tank:	25L
Fuel:	Unleaded Petrol
Maximum Power Rating:	5500W
Maximum Running Time:	9hr
Motor Power:	13hp/9.7kW
Motor Type:	4-Stroke Petrol
Nett Weight:	79.4kg
Noise Rating:	97dB(A)
Oil Capacity:	1.1L
Output:	230V/110V~50Hz
Recommended Oil:	SAE 10W-30

4. ASSEMBLY

4.1. WHEEL ASSEMBLY (Refer to parts list).

1. Place the bottom of the generator cradle on a flat even surface. Temporarily place unit on blocks to ease assembly.
2. Slide axle through both mounting braces on the cradle frame as shown (Fig 1).
3. Slide a wheel (with the inflation valve facing out) and a flat washer over the axle, then secure the wheel with a retaining pin (Fig 2.Fig 3.Fig 4).
4. Install the other wheel in the same manner.

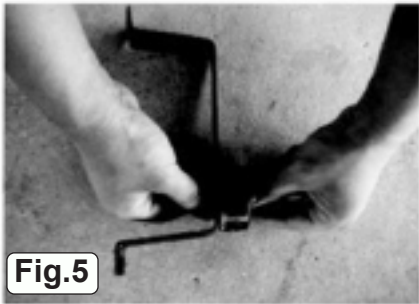
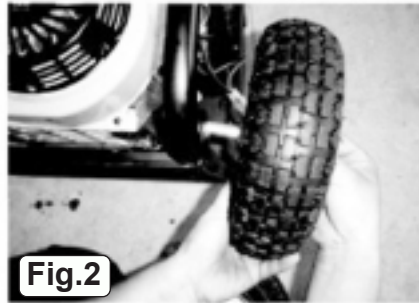

5. FEATURES

1	Fuel tap
2	230V AC output
3	110V AC output
4	DC circuit breaker
5	Voltmeter
6	Ignition switch
7	Recoil starter
8	110V to 230V switch
9	Engine oil light warning
10	DC 12V
11	Ground terminal
12	Air filter
13	Oil filter
14	Choke



6. PREPARATION

6.1. PREPARATION BEFORE STARTING

❑ **WARNING!** The generator comes without oil please fill to the appropriate level. See maintenance section for level check.

6.2. OIL CHECKS

6.2.1. Always check the engine oil level with the generator on a flat, level surface before starting or refilling the machine.

6.2.2. If an insufficient amount of engine oil is used, damage to the engine may result.

6.2.3. **DO NOT** overfill the engine with oil check on dipstick .

6.3. LOW OIL PRESSURE SWITCH

6.3.1. This generator is equipped with a low oil pressure switch this system will stop the engine automatically when the oil pressure falls below the minimum pressure required.

6.3.2. This prevents damage such as bearing seizures etc. However, this should not be relied upon and the engine oil level should be checked and topped up if required, daily.

* **DO NOT** exceed individual socket amp ratings.

6.4. FUEL

* **DO NOT** refill tank while engine is running or HOT.

* **DO NOT** overfill the petrol tank and make sure the filler cap is securely closed after refuelling. Always leaving a 25mm gap above the fuel level.

6.4.1. Take care not to spill fuel when refuelling. If any fuel is spilled, make sure the area is clean and dry before starting the engine.

6.4.2. Wear suitable P.P.E.

6.4.3. Keep dust and water out of the fuel.

6.4.4. When filling the fuel tank from drums, make sure that no dust or water is mixed in with the fuel. This can cause serious damage to the engine.

6.5. GROUND TERMINAL

6.5.1. Is to prevent electrical shock from faulty appliances, the generator should be grounded. Connect a length of heavy wire between the ground terminal and the ground source. The generator has a system ground that connects the generator frame components to the ground terminals in the AC output receptacles. The system ground is not connected to the AC neutral wire. If the generator is tested by a receptacle tester, it will not show the same ground circuit condition as for a home receptacle.

6.5.2. The generator ground terminal is connected to the panel of the generator, the metal non-current carrying parts of the generator, and the ground terminals of each receptacle. Before using the ground terminal, consult a qualified electrician, electrical inspector or local agency having jurisdiction for local codes or ordinances that apply to the intended use of the generator **NOTE:** Generator should be earthed to prevent electric shocks. Turn off the main breaker switch and remove all loads. Before starting the engine, be sure to switch OFF any appliances connected to it. Ensure that the breaker switch is OFF before switching between 110v/230v.

6.6. SPECIAL REQUIREMENTS

6.6.1. Please consult a qualified electrician, electrical inspector, or the local agency having jurisdiction.

6.6.2. In some areas, generators are required to be registered with local utility companies.

If the generator is used at a construction site, there may be additional regulations which must be observed.

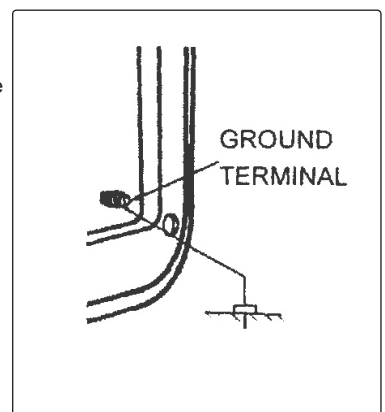

7. OPERATION

STARTING

7.1. ENGINE SWITCH TO START AND STOP THE ENGINE

Switch position:

OFF: To Stop the engine. Key can be removed/inserted.

ON: To run the engine.

START: To start the engine by turning the starter motor.

With electric start

With-out electric start

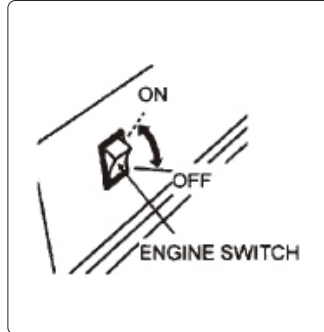
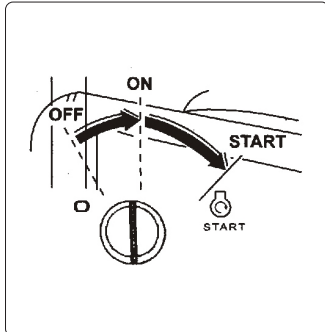

- 7.1.1. Return the key to the ON position once the engine has started. Do not use the starter for more than 5 seconds at a time. If the engine fails to start, release the switch and wait 10 seconds before operating the starter again.

7.2. RECOIL STARTER

To start the engine, pull the starter grip lightly until resistance is felt, then pull briskly.

NOTE: DO NOT allow the starter to snap back against the engine. Return it gently to prevent damage to the starter.

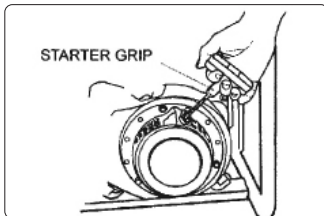

7.3. FUEL VALVE

- 7.3.1. The fuel valve is located between the fuel tank and carburettor. When the valve lever is in the ON Position, fuel is allowed to flow from the fuel tank to the carburettor. Be sure to return the lever to OFF after stopping the engine.

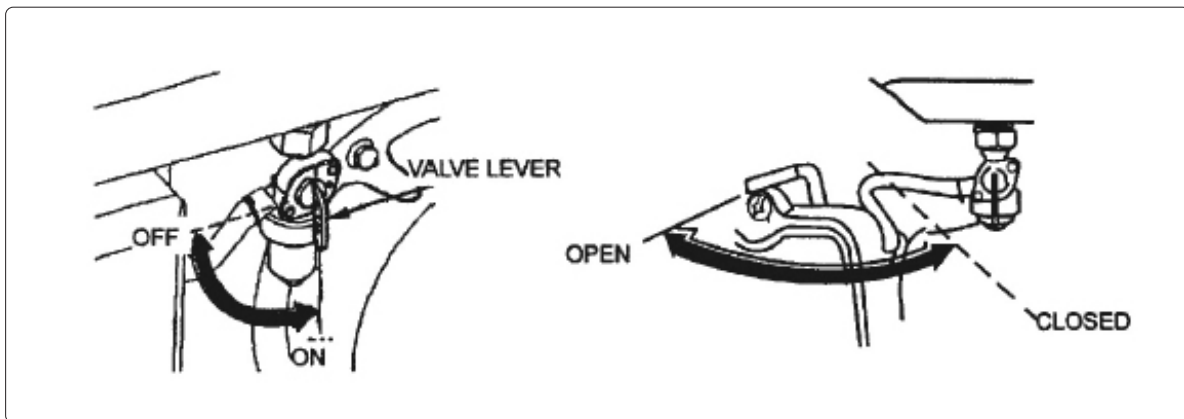

❑ **WARNING! NEVER REFUEL THE FUEL TANK WHILST THE ENGINE IS STILL RUNNING.**

7.4. CHOKE

- 7.4.1. The choke is used to provide an enriched fuel mixture when starting a cold engine. It can be opened and closed by operating the choke lever or choke rod manually. Move the lever or the rod to the CLOSE position to enrich the mixture.

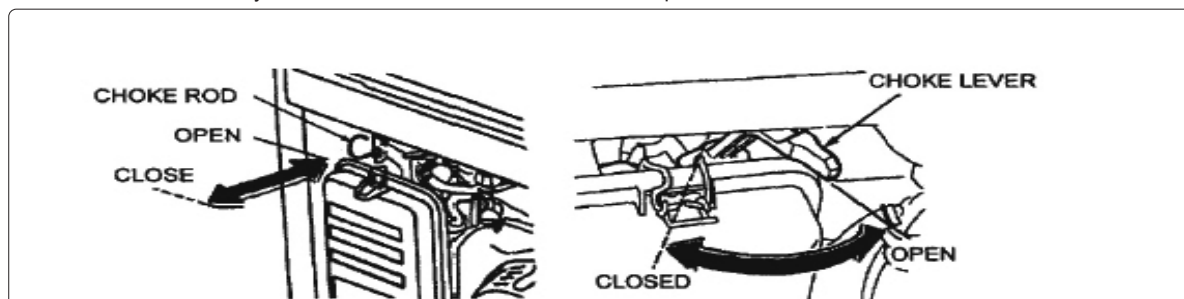

7.5. CIRCUIT BREAKER

- 7.5.1. The circuit breaker will automatically switch OFF if there is a short circuit or a significant overload of the generator at the receptacle. If the circuit breaker is switched Off automatically, check that the appliance is working properly and does not exceed the rated load capacity of the circuit before switching the circuit breaker ON again. The circuit breaker may be used to switch the generator power ON or OFF.

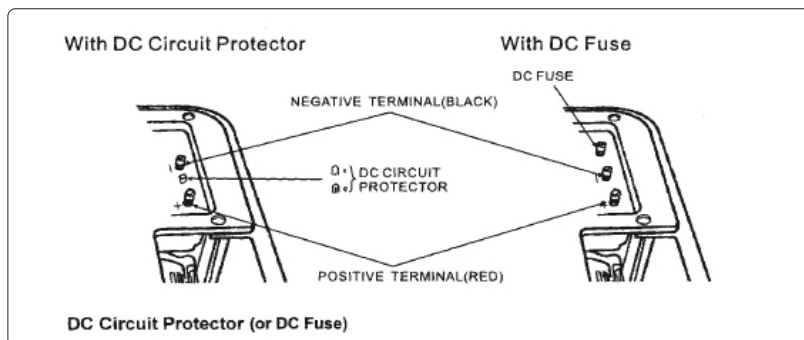
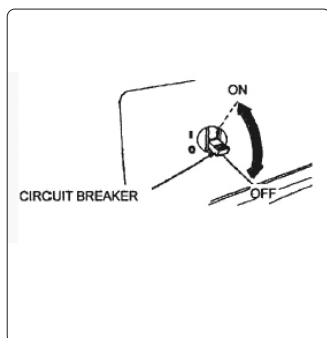

7.6. OIL ALERT SYSTEM

The oil alert system is designed to prevent engine damage caused by an insufficient amount of oil in the crankcase. Before the oil level in the crankcase can fall below a safe limit, the oil alert system will automatically shut down the engine (the engine switch will remain in the ON position). The oil alert system shuts down the engine and the engine will not start. If this occurs, first-check engine oil.

7.7. CONNECTIONS TO A BUILDING'S ELECTRICAL SYSTEM

- 7.7.1.1. Connections for standby power to a building's electrical system must be made by a qualified electrician. The connection must isolate the generator power from utility power, and must comply with all applicable laws and electrical codes.

- ❑ **WARNING!** Improper connections to a building's electrical system, can allow electrical current from the generator to feedback into the Utility lines. Such feedback may electrocute utility company workers or others who contact the lines during a power outage. Consult the utility company or a qualified electrician.
- ❑ **WARNING!** Improper connections to a building's electrical system can allow electrical current from the utility company to feedback into the generator. When utility power is restored, the generator may explode, burn, or cause fires in the building's electrical system.

7.8. AC APPLICATIONS

7.8.1. BEFORE CONNECTING AN APPLIANCE OR POWER CORD TO THE GENERATOR:

- 7.8.1.1. Make sure that it is in good working order. Faulty appliances or power cords can create a potential for electrical shock. If an appliance begins to operate abnormally, becomes sluggish or stops suddenly. Turn it off immediately. Disconnect the appliance, and determine whether the problem is the appliance, or if the rated load capacity of the generator has been exceeded. Make sure that the electrical rating of the tool or appliance does not exceed that of the generator. Never exceed the maximum power rating of the generator. Power levels between rated and maximum may be used for no more than 30 minutes.

7.9. DC CIRCUIT PROTECTOR (OR DC FUSE)

- 7.9.1. The DC circuit protector (or DC Fuse) automatically shuts off the DC battery charging circuit when the DC circuit is overloaded, when there is a problem with the battery, or the connections between the battery and the generator are improper. The indicator inside the DC circuit protector button will pop out to show that the DC circuit protector has switched off. Wait a few minutes and push the button in to reset the DC circuit protector.

7.10. CONNECTING THE BATTERY CABLES

- ❑ **WARNING!** The battery gives off explosive gases; keep spark, flames and cigarettes away. Provide adequate ventilation when charging or using batteries.
- ❑ **WARNING! DO NOT** start the generator while the battery is on charge and charging cables are connected, or try and connect charging cables when generator is running. Or the generator may be damaged.

- 7.10.1. Before connecting charging cables to the battery, disconnect the generator's grounded battery cable.

- 7.10.2. Connect the positive (+) battery cable to the battery positive (+) terminal. Connect the negative (-) battery cable to the battery negative (-) terminal.

- 7.10.3. Start the generator.

7.11. DISCONNECTING THE BATTERY CABLES

- 7.11.1. Stop the engine,
7.11.2. Disconnect the negative (-) battery cable from the generator negative (-) terminal.
7.11.3. Disconnect the positive (+) battery cable from the generator positive (+) terminal.

8. OPERATION

8.1. HIGH ALTITUDE OPERATION

At high altitude, the carburettor air-fuel mixture will be excessively rich. Performance will decrease, and fuel consumption will increase. High altitude performance can be improved by installing a smaller diameter main jet in the carburettor and readjusting the pilot screw. If you always operate the engine at altitudes higher than 5000 feet (1500 meters) above sea level, have an authorised generator dealer perform this carburettor modification. Even with suitable carburettor jetting, engine horsepower will decrease approximately 3.5% for each 1000 foot (300 meter) increase in altitude. The effect of altitude on horsepower will be greater if no carburettor modification is made.

NOTE: If the engine has been jetted for high altitude and is used at a lower altitude, the lean air fuel mixture will reduce performance and may over-heat and seriously damage the engine.

8.2. PRE-OPERATION CHECK

8.2.1. ENGINE OIL

- 8.2.2. Engine oil is a major factor affecting engine performance and service life. Non-detergent and 2-stroke engine oils will damage the engine and are not recommended.

- 8.2.3. Check the oil level **BEFORE EACH USE** with the generator on a level surface with, the engine stopped. Use 4-stroke oil, or equivalent high TEMP detergent, premium quality motor oil certified to meet or exceed U.S. automobile manufacturer's requirements for Service Classification SG, SF/CC, CD. Motor oils classified SG, SF/CC, CD will show this designation on the container. SAE 10W-30 is

recommended for general temperature use. Other viscosities Shown in the chart may be used when the average temperature in your area is within the indicated range.

8.3. INDICATED RANGE ON THE DIPSTICK

- 8.3.1. Remove the oil filler cap and wipe the dipstick clean.
- 8.3.2. Check the oil level by inserting the dipstick into the filler neck without screwing it in.
- 8.3.3. If the level is low, add the recommended oil to the upper mark on the dipstick.

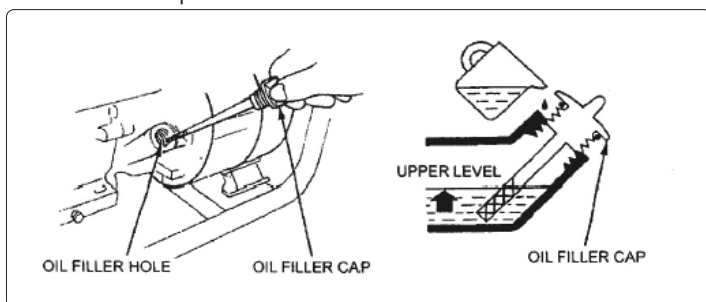
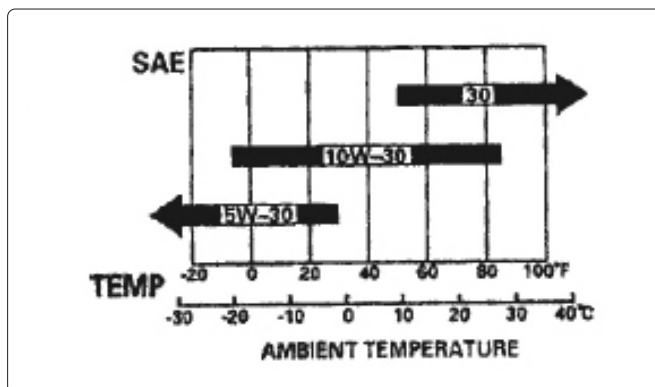

8.4. FUEL

- 8.5. Check the fuel level gauge.
- 8.6. Refill the tank if the fuel level is low. Do not fill above the shoulder of the fuel strainer.
- 8.7. Use gasoline with a pump octane rating of 86 or higher.
- 8.8. We recommend unleaded gasoline because it produces fewer engine and spark plug deposits and extends exhaust system life.
- 8.9. Never use stale or contaminated gasoline or oil/gasoline mixture. Avoid getting dirt or water in the fuel tank.
- 8.10. Occasionally you may hear light "spark knock" or "pinging" (metallic tapping noise) while operating under heavy loads. This is no cause for concern. If spark knock or pinging occurs at a steady engine speed, under normal load, change brands of petrol. If spark knock or pinging persists, see an authorised Sealey stockist.

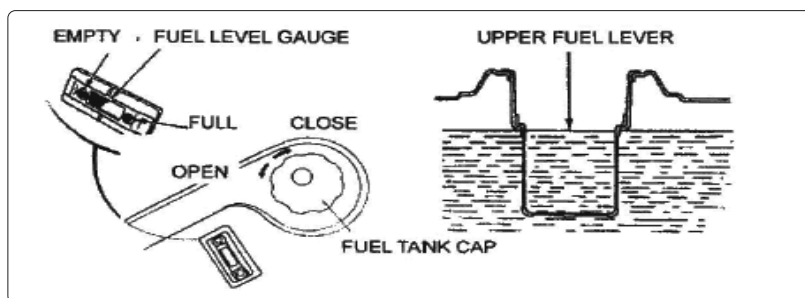

WARNING! Ensure the engine is off before performing any service. If the engine must be run, make sure that the area is well ventilated. The exhaust contains poisonous carbon monoxide gas. Maintenance After engine has been run prior to changing the oil will be very hot. Wear appropriate PPE. **DO NOT** allow any dust, dirt or any other debris enter oil or crankcase.

WARNING! Running the engine with persistent spark knock or pinging can cause engine damage.

8.11. STARTING THE ENGINE

- 8.11.1. Make sure that the AC circuit breaker is in the OFF position.
- 8.11.2. The generator may be hard to start if a load is connected.
- 8.11.3. Turn the fuel valve to the ON position.
- 8.11.4. Turn the choke lever or to the CLOSE position, or pull the choke rod out to the CLOSE position
- 8.11.5. Start the engine

8.12. RECOIL STARTING

- 8.12.1. Turn the engine switch to the ON position.
- 8.12.2. Pull the starter grip until compression is felt, then pull briskly.
NOTE: DO NOT allow the starter grip to snap back against the engine.
- 8.12.3. Return it gently to prevent damage to the starter or housing.

8.13. ELECTRIC STARTING

- 8.13.1. Turn the engine switch to the START position and hold it there for 5 seconds or until the engine starts.
- 8.13.2. When the engine starts, allow the engine switch to return to the ON position.
- 8.13.3. Turn the choke lever or push the choke rod to the OPEN position as the engine warms up.

8.13.4. STOPPING THE ENGINE

8.14. IN AN EMERGENCY

- 8.14.1. To stop the engine in an emergency, move the engine switch to the OFF position.

8.15. IN NORMAL USE

- 8.15.1. Turn the AC circuit breaker to the OFF position.
- 8.15.2. Disconnect the DC battery charging cables.
- 8.15.3. Turn the engine switch to the OFF position.
- 8.15.4. Turn the fuel valve to the OFF position.

8.16. CHECK LIST WHILST RUNNING

- 8.17. During each use make sure that there are no abnormal sounds or vibration.
- 8.18. Check that the engine is running smoothly normally.
- 8.19. Check that there is no excessive smoke from the exhaust after ten minutes of running, and the engine has reached working temperature.
- 8.20. Check that there are no oil or fuel leaks.

- 8.21. If you notice any of the above, stop the engine and locate the fault. Please contact your Sealey Stockist.
NOTE: Operating the starter motor for more than 5 seconds can damage the motor. If the engine fails to start, release the switch And wait 10 seconds before operating the starter again. If the speed of the starter motor drops after a period of time, it indicates that the battery should be recharged.
- 8.22. CONNECTING EQUIPMENT**
- 8.23. Connecting the loads with the largest motor, then the smaller items.
- 8.24. If the generator is overloaded the main breaker will trip.
- 8.25. To reset the breaker do the following; Turn OFF and disconnect all loads. Reset breaker, and add load onto the circuit to within 50% to 75% of rated output. Wait a few minutes before resuming operation.

9. MAINTENANCE

- 9.1. Good maintenance is essential for safe, economical, and trouble-free operation. It will also help reduce air pollution.
- WARNING!** Exhaust gas contains poisonous carbon monoxide. Shut off the engine before performing any maintenance. If the engine must be run, make sure the area is well ventilated. Periodic maintenance and adjustment is necessary to keep the generator in good operating condition. Perform the service and inspection at the intervals shown in the Maintenance schedule below.

REGULAR SERVICE PERIOD Performed at every indicated month or operating hour interval, whichever comes first.		EVERY USE	FIRST MONTH OR 20 HOURS	EVERY THREE MONTHS OR 50Hrs	EVERY SIX MONTHS OR 100Hrs	EVERY YEAR OR 300Hrs
Engine oil	Check level	O				
	Change		O		O	
Air cleaner	Check	O				
	Clean			O (1)		
Sediment Cup	Clean				O	
Spark plug	Check-Clean				O	
Spark arrester	Clean				O	
Valve clearance	Check-Adjust					O (2)
Fuel tank and strainer	Clean					O (2)
Fuel line	Check	Every 2 years (Replace if necessary) (2)				

NOTE: Service more frequently when used in dusty areas. These items should be serviced by an authorized generator dealer, unless the owner has the proper tools and is mechanically proficient. For professional commercial use, long hours of operation to determine proper maintenance intervals.

9.2. TOOL KIT

- 9.3. The tools supplied with the generator will help you to perform the owner maintenance procedures listed on the following pages. Always keep this tool kit with the generator.

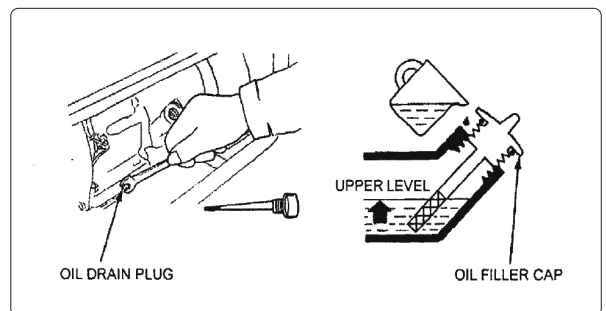
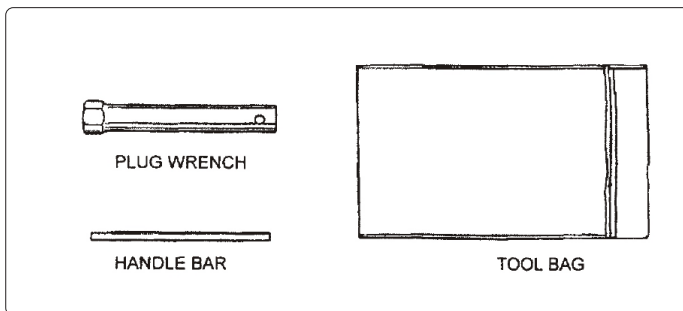

9.4. ENGINE OIL CHANGE

- 9.4.1. Drain the oil while the engine is warm to assure complete and rapid draining.
- 9.4.2. Remove the drain plug and sealing washer, oil filler cap, and drain the oil.
- 9.4.3. Reinstall the drain plug and sealing washer. Tighten the plug securely.
- 9.4.4. Refill with the recommended oil and check the oil level.

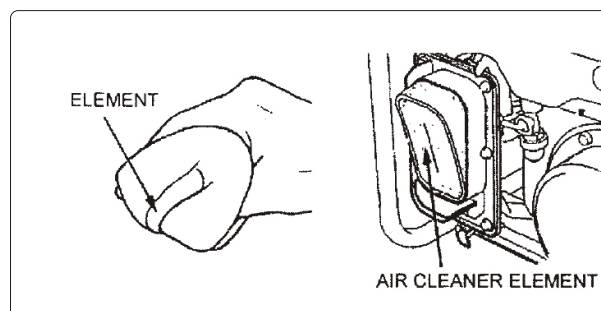
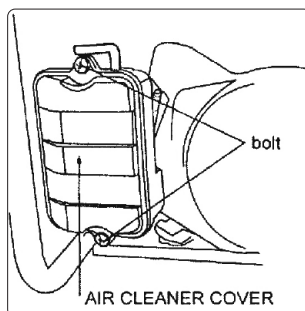

9.5. AIR CLEANER SERVICE

- WARNING!** A dirty air cleaner will restrict air flow to the carburettor. To prevent carburettor malfunction, service the air cleaner regularly. Service more frequently when operating the generator in extremely dusty areas.

NOTE: Never run the generator without the air cleaner. Rapid engine wear will result.

- 9.5.1. Unsnap the air cleaner cover clips, remove the air cleaner cover, and remove the element.

- 9.5.2. Wash the element in a solution of household detergent and warm water, then rinse thoroughly; or wash in non-flammable or high flash point solvent. Allow the element to dry thoroughly.
- 9.5.3. Soak the element in clean engine oil and squeeze out the excess oil. The engine will smoke during initial start-up if too much oil is left in the element.
- 9.5.4. Reinstall the air cleaner element and the cover.

9.6. FUEL SEDIMENT CUP CLEANING

- 9.6.1. The sediment cup prevents dirt or water which may be in the fuel tank from entering the carburettor. If the engine has not been run for a long time, the sediment cup should be cleaned.
- 9.6.2. Turn the fuel valve to the OFF position. Remove the sediment cup, and o-ring.
- 9.6.3. Clean the sediment cup, and a-ring, in non-flammable or high flash point solvent.
- 9.6.4. Reinstall a-ring, and sediment cup.
- 9.6.5. Turn the fuel valve ON and check for leaks.

9.7. SPARK PLUG SERVICE

- 9.7.1. Recommended spark plugs: F5T or F6TC or F7T JC or other equivalents.
- 9.7.2. To ensure proper engine operation, the spark plug must be properly gapped and free of deposits.
- 9.7.3. If the engine has been running, the exhaust will be very hot. Be careful not to touch the exhaust.
- 9.7.4. Remove the spark plug cap.
- 9.7.5. Clean any dirt from around the spark plug base.
- 9.7.6. Use the wrench supplied in the tool kit to remove the spark plug.
- 9.7.7. Visually inspect the spark plug. Discard it if the insulator is cracked or chipped.
- 9.7.8. Clean the spark plug with a wire brush if it is to be reused.
- 9.7.9. Measure the plug gap with a feeler gauge. Correct as necessary by carefully bending the side electrode.
- 9.7.10. The gap should be: 0.70-0.80 mm (0.028-0.031 in).
- 9.7.11. Check that the spark plug washer is in good condition, and thread the spark plug in by hand to prevent cross-threading.
- 9.7.12. After the spark plug is seated, tighten with a spark plug wrench to compress the washer. If installing a new spark plug, tighten 1/2 tum after the spark plug seats to compress the washer. If reinstalling a used spark plug, tighten 1/8 - 1/4 tum after the spark plug seats to compress the washer.

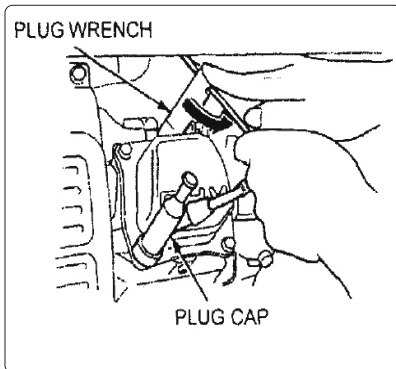
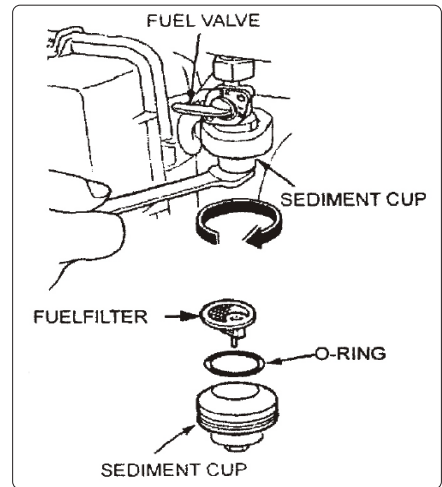

10. TROUBLESHOOTING

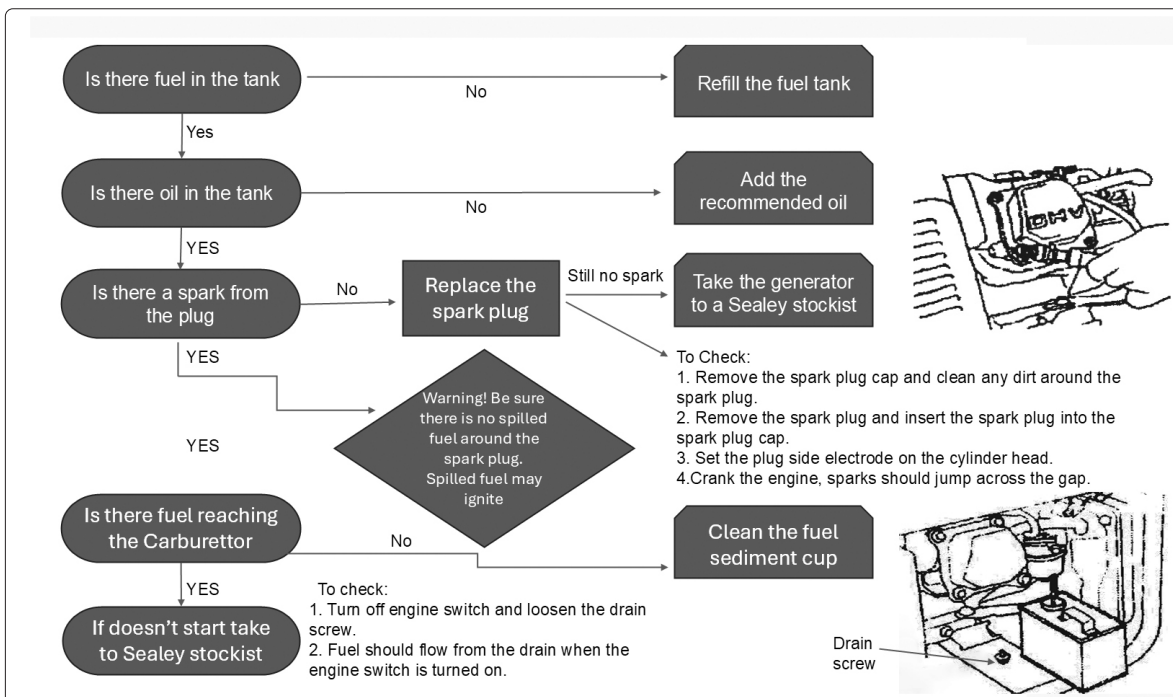

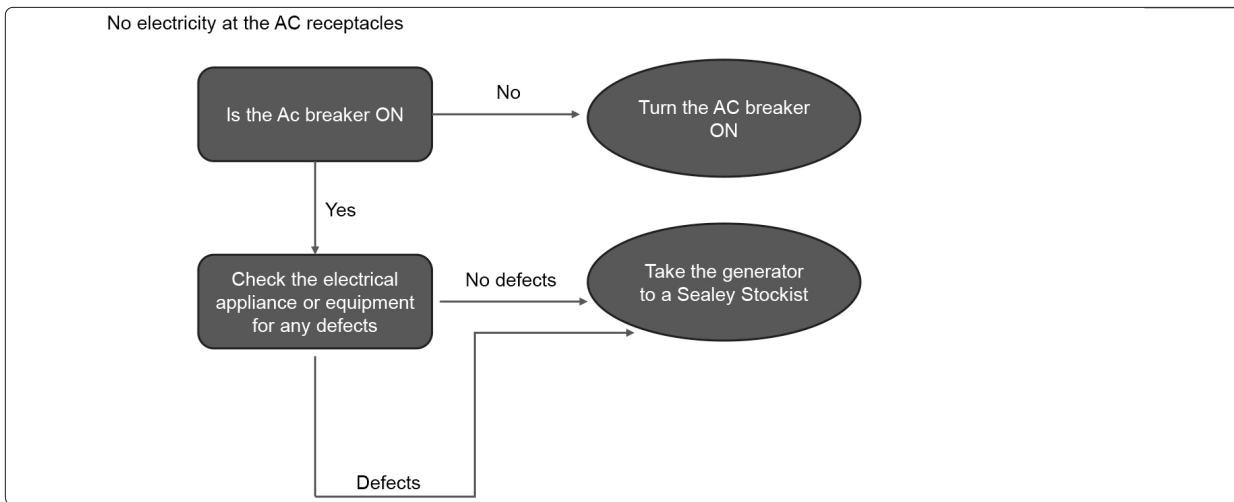

11. TRANSPORTING / STORAGE

11.1. When transporting the generator, turn the engine switch and the fuel valve OFF. Keep the generator level to prevent fuel spillage. Fuel vapor or spilled fuel may ignite.

❑ **WARNING!** Contact with a hot engine or exhaust system can cause serious burns or fires. Let the engine cool before transporting or storing the generator.

Take care not to drop or strike the generator when transporting. **DO NOT** place heavy objects on the generator.

Before storing the unit for an extended period:

1. Be sure the storage area is free of excessive humidity and dust. 2. Service according to the table below.

STORAGE TIME	RECOMMENDED SERVICE PROCEDURE TO PREVENT DIFFICULT STARTING
Less than 1 month.	No preparation required.
2 months to 1 year.	Fill with fresh petrol and add petrol cleaner. Drain the carburettor float bowl. Drain the fuel sediment cup.
1 year or more.	Fill with fresh petrol and add petrol cleaner. Drain the carburettor float bowl. Drain the fuel sediment cup. Remove the spark plug. Put a tablespoon of engine oil into the cylinder. Turn the engine slowly with the pull rope to distribute the oil. Reinstall the spark plug. Change the engine oil. After removal from storage, drain the stored petrol into a suitable container, and fill with fresh gasoline before starting.
Use petrol conditioners that are formulated to extend storage life. Contact your authorised Sealey stockist for conditioner recommendations.	

11.2. Drain the carburettor by loosening the drain screw. Drain the petrol into a suitable container.

❑ **WARNING!** Gasoline is extremely flammable and is explosive under certain conditions. Perform this task in a well ventilated area with the engine turned off. Do not smoke or allow flames or sparks in the area during this procedure.

11.3. Change the engine oil.

11.4. Remove the spark plug, and pour about a tablespoon of clean engine oil into the cylinder. Crank the engine several revolutions to distribute the oil, then reinstall the spark plug.

11.5. Slowly pull the starter grip until resistance is felt. At this point, the piston is coming up on its compression stroke and both the intake and exhaust valves are closed.

11.6. Storing the engine in this position will help to protect it from internal corrosion.

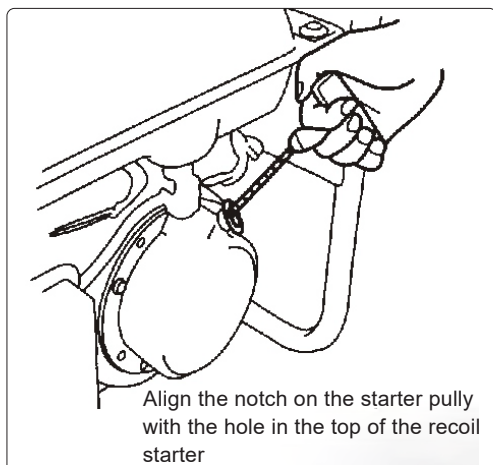

12. WIRING DIAGRAM

3-5Kw Key start generator Diagram

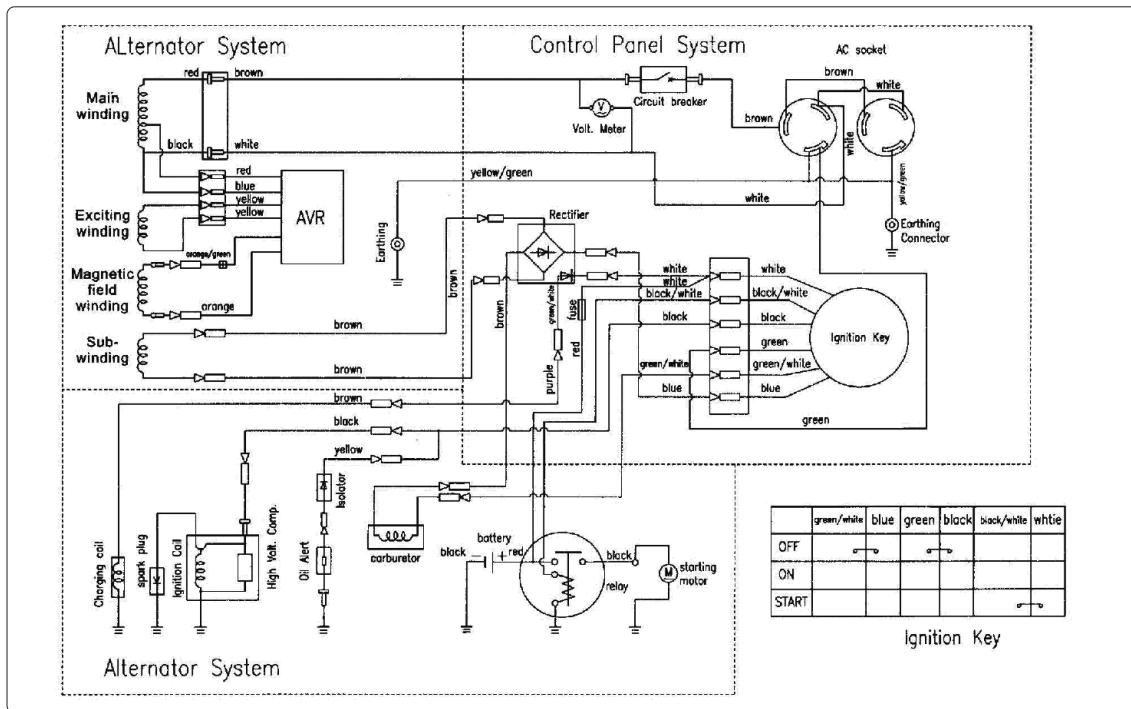

ENVIRONMENT PROTECTION

Recycle unwanted materials instead of disposing of them as waste. All tools, accessories and packaging should be sorted, taken to a recycling centre and disposed of in a manner which is compatible with the environment. When the product becomes completely unserviceable and requires disposal, drain any fluids (if applicable) into approved containers and dispose of the product and fluids according to local regulations.



REGISTER YOUR PURCHASE HERE

Note: It is our policy to continually improve products and as such we reserve the right to alter data, specifications and component parts without prior notice. Please note that other versions of this product are available. If you require documentation for alternative versions, please email or call our technical team on technical@sealey.co.uk or 01284 757505.

Important: No Liability is accepted for incorrect use of this product.

Warranty: Guarantee is 12 months from purchase date, proof of which is required for any claim.

Jack Sealey Ltd t/a Sealey Group, Kempson Way, Suffolk Business Park, Bury St Edmunds, Suffolk, IP32 7AR UK

Jack Sealey (EU) Ltd t/a Sealey Group, Farney Street, Carrickmacross, Co. Monaghan, A81 PK68 Ireland

Tel: 01284 757500 · Email: sales@sealey.co.uk · Web: www.sealey.co.uk